

Quick Guide

Nano Plus Inverter



V.1.0

1 Introduction

The Nano Plus is a long-run backup power system for home and small office applications. It provides comprehensive protection in a small and economic package. With external battery packs, it can work as inverter for long-term power backup. Besides, its wide acceptable input range features generator compatible.

The unit is more compact and offers greater comprehensive power protection against surges and spikes. It will continue providing stable power to connected equipment. Its embedded microprocessor controller guarantees high reliability and it's perfect for any home or small office application.

2 Product Overview

Front View:

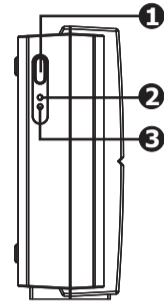

- ① Power switch
 - ② UPS status indicator
 - ③ Fault/Battery status indicator
- (Check the Indicator & Alarm Table for the details)

Back View:

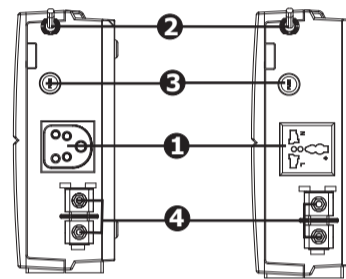

India Type

Universal Type

- ① Output receptacles
- ② AC input
- ③ Input breaker
- ④ External battery connectors

3 Important Safety Warnings

Before using the unit, please read all instructions and cautionary markings on the unit, this manual and the batteries.

General Precaution-

Conventions used:

WARNING! Warnings identify conditions or practices that could result in personal injury;

CAUTION! Caution identify conditions or practices that could result in damaged to the unit or other equipment connected.

CAUTION! This unit contains more than one live circuit (batteries & AC line). Power may be present at more than one source. To reduce the risk of electrical shock, disconnect both AC and DC power from the unit before attempting any maintenance or replacement inside of the unit. Turning off the unit will not reduce this risk.

CAUTION! To reduce risk of injury, only use qualified batteries from qualified distributors or manufacturers. Any unqualified batteries may cause damage and injury. Do NOT use old or overdue batteries. Please check the battery type and date code before installation to avoid damage and injury.

WARNING! It's very important for system safety and efficient operation to use appropriate external battery cable. To reduce risk of injury, external battery cables should be UL certified and rated for 75 C or higher. And do NOT use copper cables less than 18AWG. Below is the external battery cable reference according to system requirements.

Table 1 Minimum Recommended Battery Cable Size versus Length

Model	Typical Amp.	1-4 Feet (one-way)	Dia-mm
Nano Plus 400	25 A	AWG 12	2.05

WARNING! Provide ventilation to outdoors from the battery compartment. The battery enclosure should be designed to prevent accumulation and concentration of hydrogen gas at the top of the compartment.

CAUTION! Use insulated tools to reduce the chance of short-circuit when installing or working with the inverter, the batteries, or other equipments attached to this unit.

CAUTION! For battery installation and maintenance, read the battery manufacturer's installation and maintenance instructions prior to operating.

Personnel Precaution -

CAUTION! If you need to remove a battery, make sure all accessories are off so you don't cause a spark.

CAUTION! Make sure the area around the battery is well ventilated.

CAUTION! Careful to reduce the risk or dropping a metal tool on the batteries. It could spark or short circuit the batteries and could cause an explosion.

CAUTION! Remove personal metal items such as rings, bracelets, necklaces, and watches when working with batteries. Batteries can produce a short circuit current high enough to make metal melt, and could cause severe burns.

CAUTION! Avoid touching eyes while working near batteries.

CAUTION! Have plenty of fresh water and soap nearby in case battery acid contacts skin, clothing, or eyes.

CAUTION! NEVER smoke or allow a spark or flame in vicinity of a battery.

CAUTION! If a remote or automatic generator start system is used, disable the automatic starting circuit or disconnect the generator to prevent accident during servicing.

4 Specifications

Model	Nano Plus 400
CAPACITY	400 VA / 200 W
INPUT	
Voltage	220/230/240 VAC
Voltage Range	180-270 VAC
OUTPUT	
Voltage Regulation (Bat. Mode)	±10%
Transfer Time	2-6 ms
Waveform	Simulated sine wave
BATTERY	
Battery Voltage	12 VDC
Floating Voltage	13.7 V ± 1.5%
PHYSICAL	
Dimension (DxWxH mm) (@ vertically stand)	228 x 82.5 x 207
Net Weight (kgs)	1

5 Installation

NOTE: Before installation, please inspect the unit. Be sure that nothing inside the package is damaged.



IMPORTANT WARNINGS BEFORE MAKING BATTERY CONNECTION!!

CAUTION!! Remove personal metal items such as rings, bracelets, necklaces, and watches when working with batteries.

CAUTION!! For the user operation safety, we strongly recommend that you should use tapes to isolate the battery terminals before you start to operate the unit. Please refer to below instruction for further information.

Internal Battery Section

- Step 1-Turn off the unit and unplug the unit to prevent electrical shock or sparks.
- Step 2-Remove 4 screws located on the bottom of the unit to open the unit. To prevent any shocks, please do NOT touch any inside components.
- Step 3-Check if there is an internal battery inside. If yes, removing battery wires from internal battery first.

NOTE: Do NOT make the battery short circuited, or it will cause the danger of burning. To prevent any shocks, do NOT touch any inside components.

A. Replace Internal Battery

- Step 1-Remove the old battery from the case.
- Step 2-Make sure the new battery is the same type and nominal voltage to the old battery.
- Step 3-Connect the battery cables to the internal battery.
RED cable to the positive terminal (RED) of the battery;
BLACK cable to the negative terminal (BLACK) of the battery.
- Step 4-Assemble the case with 4 screws.
- Step 5-Power on the unit.

B. Modify Internal Battery Connection to External Battery Connection

- Step 1-Remove the old battery from the case.
- Step 2-Connect battery cable to external battery terminal on PCB.
RED cable to W7 : the positive terminal (RED+)(BAT+);
BLACK cable to W5: the negative terminal(BLK-)(BAT-)
- Step 3-Assemble the case with 4 screws.
- Step 4-Follow the procedures of **External Battery Connection** Section listed below.
- Step 5-After completing external battery connection, power on the unit.

C. Modify External Battery Connection to Internal Battery Connection

- Step 1-Before disassembling the unit, disconnect the external battery and external battery cable first.
- Step 2-Disassemble the unit.
- Step 3-Disconnect the internal battery cable from the external battery terminal (W5 and W7).
- Step 4-Put internal battery into the case. Make sure the voltage of the new battery is equal to the nominal battery DC voltage of the unit.

Model	Nominal Battery DC Voltage
Nano Plus 400	12 VDC

- Step 5-Connect the battery cable to the internal battery.
RED cable to the positive terminal (RED) of internal battery;
BLACK cable to the negative terminal (BLACK) of internal battery.
- Step 6-Assemble the unit with 4 screws.
- Step 7-Power on the unit.

External Battery Connection

- Step 1- **Following battery polarity guide printed near the battery terminal!**
Place the external battery cable ring terminal over the battery terminal.
RED cable to the positive terminal (+);
BLACK cable to the negative terminal (-).

WARNING! Please use the appropriate battery cable. Please refers to **Important Safety Warnings Section** for the details.

- Step 2- Tight the screws. Do NOT place anything between the flat part of battery terminal and the battery cable ring terminal, or overheating may occur.
 - Step 3- Connect battery cables to the external batteries.
- Note:** For the user operation safety, we strongly recommend that you should use tapes to isolate the battery terminals before you start to operate the unit.

1)Single battery connection(Refer to Fig. 1):

When using a single battery, its voltage must be equal to the Nominal DC Voltage of the unit (see below Table 1).

RED cable to the positive terminal (+) of external batteries;
BLACK cable to the negative terminal (-) of negative batteries.

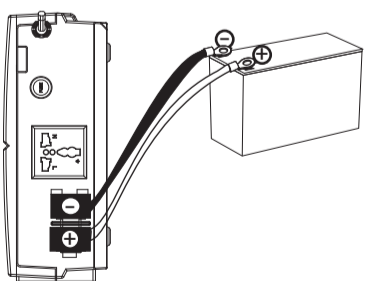

Fig. 1

Table 1

Model	Nominal Battery DC Voltage
Nano Plus 400	12 VDC

2)Multiple batteries in series connection(Refer to Fig. 2):

All batteries must be equal in voltage and amp hour capacity. The sum of their voltages must be equal to the nominal DC Voltage of the unit.

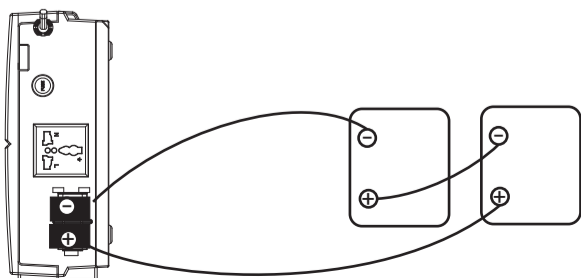

Fig. 2

3)Multiple batteries in parallel connection (Refer to Fig. 3):

Each battery voltage must be equal to the Nominal DC Voltage of the unit.

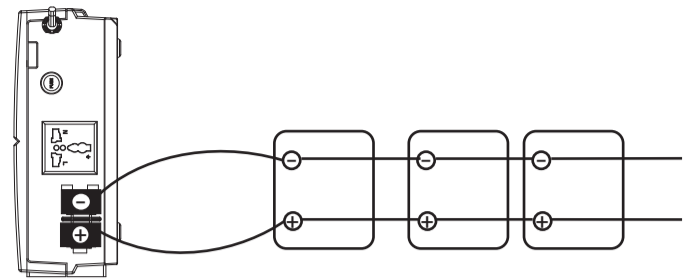

Fig. 3

Mounting the Unit

The unit can be mounted to a wall surface in two ways. Please follow below steps:

1. Turn off the unit before mounting.
2. Select an appropriate mounting location and mounting method.

Method 1:

- Step 1: Use a horizontal line and the length of the line must be 120 mm and mark the two ends on the wall. (see chart 1)
- Step 2: Drill two marks by screws.
- Step 3: Mount the unit by positioning the key-hole slots over the mounting screws. (see chart 2)

Method 2:

- Step 1: Use a vertical line and the length of the line must be 120 mm and mark the two ends on the wall. (See chart 3)
- Step 2: Drill two marks by screws.
- Step 3: Mount the unit by positioning the key-hole slots over the mounting screws. (see chart 4)

Method 1:

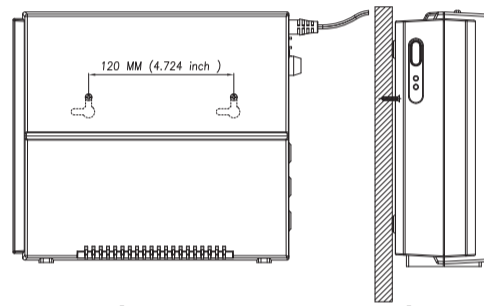

Chart 1

Method 2:

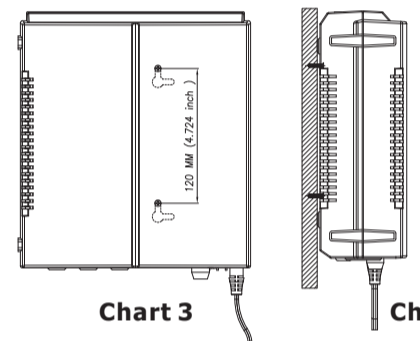

Chart 2

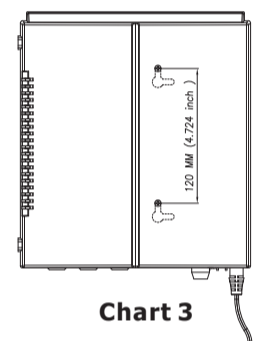

Chart 3

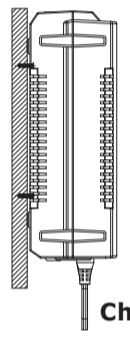

Chart 4

6 Operation

Power On/Off

Once the inverter has been properly installed, press the power switch to turn on the unit. The unit will work automatically in line mode or inverter mode according to input utility power's status. When press the power switch again, the unit will be turned off.

LED Indicators & Alarm Table for Operation

There are two indicators (Green/Red) in the front panel of the unit.

Conditions	Visual Indications	Alarm
AC mode	Green LED lighting	Off
Battery mode	Green LED flashing every 10 seconds	Sounding every 10 seconds
Low battery at battery mode	Green LED flashing every second & Red LED lighting	Sounding every second
Fault	Red LED lighting	Continuously sounding

7 Trouble Shooting

Use the table below to solve minor problems.

Problem	Probable Cause	Solution
Utility power is normal but the unit is in inverter mode.	AC input power cord is not connected well.	Check AC input power connection.
	Input breaker is blown.	Replace the input breaker.
When power fails, the backup time is shorten.	The unit is overload.	Remove some non-critical loads.
	Battery voltage is too low.	Charge the unit at least 12 hours.
	Battery capacity is not full even after charging the unit for at least 12 hours.	Check the date code of the battery. If the batteries are too old, replace the batteries.
No LED display on the front panel when the utility power is normal.	The unit is not turned on.	Press power switch to turn on the unit.
	Battery is not connected well.	Check the external battery cable and terminal. Make sure all the battery connections to the unit are all correct.
	Battery defect.	Replace the batteries.
	Battery voltage is too low.	Charge the unit at least 12 hours.

If there is any abnormal situations occur, which doesn't list above, please call the service people immediately for professional examine.