

1 Package Contents

You should have received the following items inside of package:

- UPS Unit
- Quick Guide
- Power cable (only for the IEC-type model)

2 Product Introduction

The Scudo UPS provides comprehensive protection in a small and economic package. The UPS is more compact and offers greater comprehensive power protection against surges and spikes. This UPS will continue providing stable power to connected equipment and enable to shutdown PC safely during power failure. Its embedded microprocessor controller guarantees high reliability and it's perfect for any home or small office application.

3 Product Overview

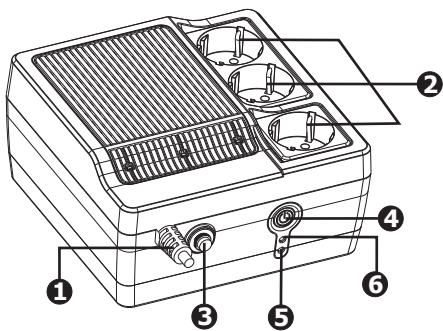

- ① AC input
 - ② Output receptacles
 - ③ Circuit breaker
 - ④ Power switch
 - ⑤ UPS status indicator
 - ⑥ Fault status indicator
- (Check the Indicator & Alarm Table for the details)

4 Installation & Initial Startup

NOTE: Before installation, please inspect the unit. Be sure that nothing inside the package is damaged.



Placement & Storage Conditions

Install the UPS in a protected area that is free of excessive dust and has adequate air flow. Please place the UPS away from other units at least 20 cm to avoid interference. Do NOT operate the UPS where the temperature and humidity is outside the specific limits. (Please check the specs for the limitations.)

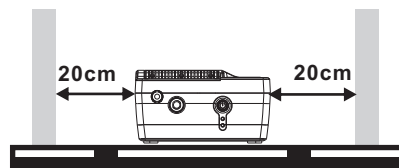

Connect to Utility and Charging

Before initial use, please plug in the AC input cord to the wall outlet and turn on the UPS for charging. For the best results, suggest to charge the battery at least 8 hours before initial use. The UPS charges its battery while connecting to the utility with power on.

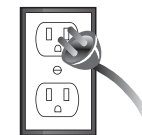

Connect the Loads

Plug in the loads to output receptacles on the rear panel of the UPS. Simply turn on the power switch of UPS unit, then devices connected to the UPS will be protected by UPS unit.

CAUTION: NEVER connect a laser printer or scanner to the UPS unit. This may cause the damage of the unit.



Turn On/Off the Unit

Turn on the UPS unit by pressing the power switch. Turn off the UPS unit by pressing again the power switch.

Indicators & Alarm Table for Operation

Conditions	Visual Indications	Alarm
AC mode	Green LED lighting	Off
Battery mode	Green LED flashing every 10 seconds	Sounding every 10 seconds
Low battery at battery mode	Green LED flashing every second & Red LED lighting	Sounding every second
Fault	Red LED lighting	Continuously sounding
Alarm for over-temperature protection	Red LED flashing every 0.5 seconds	Off

5 Important Safety Warning (SAVE THESE INSTRUCTIONS)

CAUTION! To prevent the risk of fire or electric shock, install in a temperature and humidity controlled indoor area free of conductive contaminants. (See the specifications for the acceptable temperature and humidity range.)

CAUTION! To reduce the risk of overheating the UPS, do not cover the UPS' cooling vents and avoid exposing the unit to direct sunlight or installing the unit near heat emitting appliances such as space heaters or furnaces.

CAUTION! Do not attach non-computer-related items, such as medical equipment, life-support equipment, microwave ovens, or vacuum cleaners to UPS.

CAUTION! Do not plug the UPS input into its own output.

CAUTION! Do not allow liquids or any foreign object to enter the UPS. Do not place beverages or any other liquid-containing vessels on or near the unit.

CAUTION! In the event of an emergency, press the OFF button and disconnect the power cord from the AC power supply to properly disable the UPS.

CAUTION! Do not attach a power strip or surge suppressor to the UPS.

CAUTION! If the UPS is with metal chassis, for safety purpose, grounding is a must during UPS installation in order to reduce leakage current below 3.5mA.

Attention hazardous through electric shock. Also with disconnection of this unit from the mains, hazardous voltage still may be accessible through supply from battery. The battery supply should be therefore disconnected in the plus and minus pole at the quick connectors of the battery when maintenance or service work inside the UPS is necessary.

CAUTION! Servicing of batteries should be performed or supervised by personnel knowledgeable of batteries and the required precautions. Keep unauthorized personnel away from batteries.

CAUTION! When replacing the batteries, use the same number and type of batteries.

CAUTION! Internal battery voltage is 12Vdc. Sealed, lead-acid, 6-cell battery.

CAUTION! Do not dispose of batteries in a fire. The battery may explode. Do not open or mutilate the battery or batteries. Released electrolyte is harmful to the skin and eyes.

CAUTION! Unplug the UPS prior to cleaning and do not use liquid or spray detergent.

CAUTION! A battery can present a risk of electric shock and high short circuit current. The following precaution should be observed before replacing batteries:

- 1) Remove watches, rings, or other metal objects.
- 2) Use tools with insulated handles.
- 3) Wear rubber gloves and boots.
- 4) Do not lay tools or metal parts on top of batteries.
- 5) Disconnect charging source prior to connecting or disconnecting batteries terminal.

6 Trouble Shooting

Use the table below to solve minor problems.

Problem	Probable Cause	Solution
No LED display on the front panel.	Low battery.	Charge the UPS at least 8 hours.
	Battery fault.	Replace the battery with the same type of battery.
	The UPS is not turned on.	Press the power switch again to turn on the UPS.
Alarm continuously sounds when the mains is normal.	The UPS is overload.	Remove some loads first. Before reconnecting equipment, please verify that the load matches the UPS capability specified in the specs.
	UPS fault	Return the unit to service center.
Alarm sounds every 2 seconds when the mains is normal.	Battery defect	Replace the battery with the same type of battery.
	Charging circuit is damaged.	Return the unit to service center.
When power fails, backup time is shorten.	The UPS is overload.	Remove some critical load.
	Battery voltage is too low.	Charge the UPS at least 8 hours.
	Battery defect.	Replace the battery with the same type of battery.
The mains is normal but green LED is flashing.	Power cord is loose.	Reconnect the power cord properly.

7 Specifications

Model	Scudo 400	Scudo 600
CAPACITY	400 VA / 200 W	600 VA / 300 W
INPUT		
Voltage	220/230/240 VAC	
Voltage Range	180~270 VAC	
Frequency	50 Hz	
OUTPUT		
Voltage Regulation(Bat. mode)	± 10%	
Transfer Time	2-6 ms (Typical)	
Waveform	Simulated Sine Wave	
BATTERY		
Type & Number	12 V/4 Ah x 1	12 V/5 Ah x 1
Charging Time	8 hours recover to 90% capacity	
PROTECTION		
Full Protection	Overcharge, and overload protection	
PHYSICAL		
Dimension (DxWxH mm)	166 x 161 x 86.7	
Net Weight (kgs)	2.25	2.56
ENVIRONMENT		
Humidity	0-90 %	
Temperature	0-40°C (non-condensing)	